

# Studying the Evolution of Content Providers in the Internet Core

**Esteban Carisimo**, Carlos Selmo,  
J. Ignacio Alvarez-Hamelin, Amogh Dhamdhere



# AS ecosystem mutation

## **NSFNET era (up to 1995)**

- Monolithic backbone

## **Transit era (late 1990s-2000s)**

- Densely connected Transit Network
- Eyeballs and CPs on the edge
- Tiered model

## **Content era (2010s)**

- Dominance of multimedia content
- CDNs
- Flat network

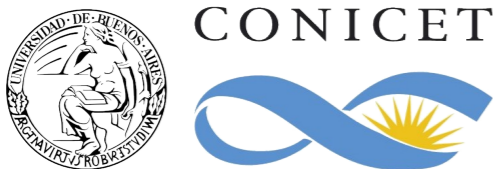

# Irruption of IXPs and CDNs

- **Deployment of CDNs**
  - General-purpose CDNs
  - Ascension of private CDNs
  - Result: CPs densely connected (core)
- **IXPs**
  - Flattening the Internet
  - Let small ASes peer directly with large ASes
  - Co-location with CDNs
- **IXPs+CDNs: Traffic impact**
  - Reduction on Transit traffic
  - Peer-to-peer traffic

# Motivations

## Google and Netflix Make Land Grab On Edge Of Internet

Many of these deals are secret, but Deepfield Networks knows of about 40 companies that are setting up their own content delivery networks with service providers, according to Craig Labovitz. But he's bound by non-disclosure agreements, and can't name names.

Wired.June 2012

<https://www.wired.com/2012/06/cdn/>



CONICET



Studying the Evolution of Content Providers in the Internet Core  
June 28th, 2018. TMA 2018  
Esteban Carisimo

# Motivations

ⓘ x

## Apple, Microsoft And Facebook Bring More Traffic To In-House CDNs, Impacting Akamai's Media Business

Oct.28.15 | About: Akamai Technologies, (AKAM)



**Dan Rayburn** ✉

Research analyst, streaming and online video

StreamingMedia [🔗](#)

Follow

(819 followers)

### Summary

- Akamai reported Q3 earnings and announced that revenue from their media delivery business would be flat or down for Q4, year-over-year.
- Akamai suggested the reason they expect media growth rates to continue to moderate in the "near term" was due to customers having "less traffic growth overall."
- The cause of what Akamai is seeing is a result of Apple, Microsoft and Facebook moving a larger percentage of their traffic to their in-house delivery networks.

October 2015

<https://seekingalpha.com/article/3613736-apple-microsoft-facebook-bring-traffic-house-cdns-impacting-akamais-media-business>



Studying the Evolution of Content Providers in the Internet Core  
June 28th, 2018. TMA 2018  
Esteban Carisimo

# Motivations

BLOG SEARCH



ADVANCED

## APNIC

Get IP ▾

Manage IP ▾

Training ▾

Events ▾

Research ▾

Community ▾

### The death of transit?

By [Geoff Huston](#) on 28 Oct 2016

Category: [Tech matters](#)

Tags: [ISPs](#), [data centres](#), [peering](#)

[12 Comments](#)



Geoff Huston, October 2016

Is there light at the end of the tunnel for transit providers?

I was struck at a [recent NANOG meeting](#) just how few presentations looked at the ISP space and the issues relating to ISP operations, and how many were looking at the data centre environment.

<https://blog.apnic.net/2016/10/28/the-death-of-transit/>

<https://labs.apnic.net/presentations/store/2017-05-25-death-of-transit.pdf>



Studying the Evolution of Content Providers in the Internet Core  
June 28th, 2018. TMA 2018  
Esteban Carisimo

# Do CPs belong to the core of the network?

- How to identify if they do? Who are they? Since when?
- Differences on cores by Region?
- How to detect “*up and coming*” CDNs?
- Correlate evolution of connectivity with well-documented business practices

# Methodology: k-core decomposition

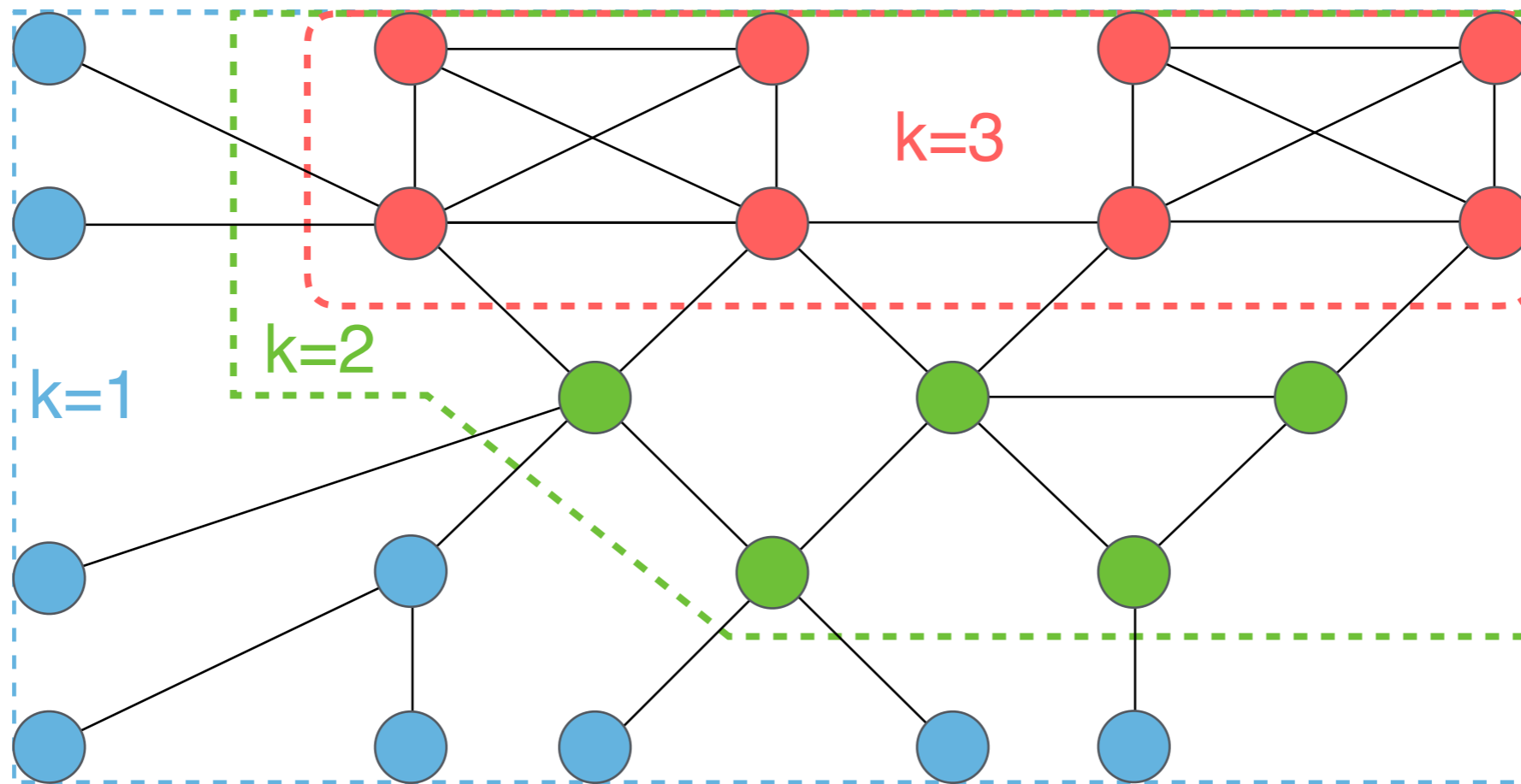

- **Core** of the network: **Densely connected ASes**
- How to know who they are: **k-cores**
- k-cores: *shell-index* given by
  - number **AND** degree of neighbors





# Methodology: k-core decomposition

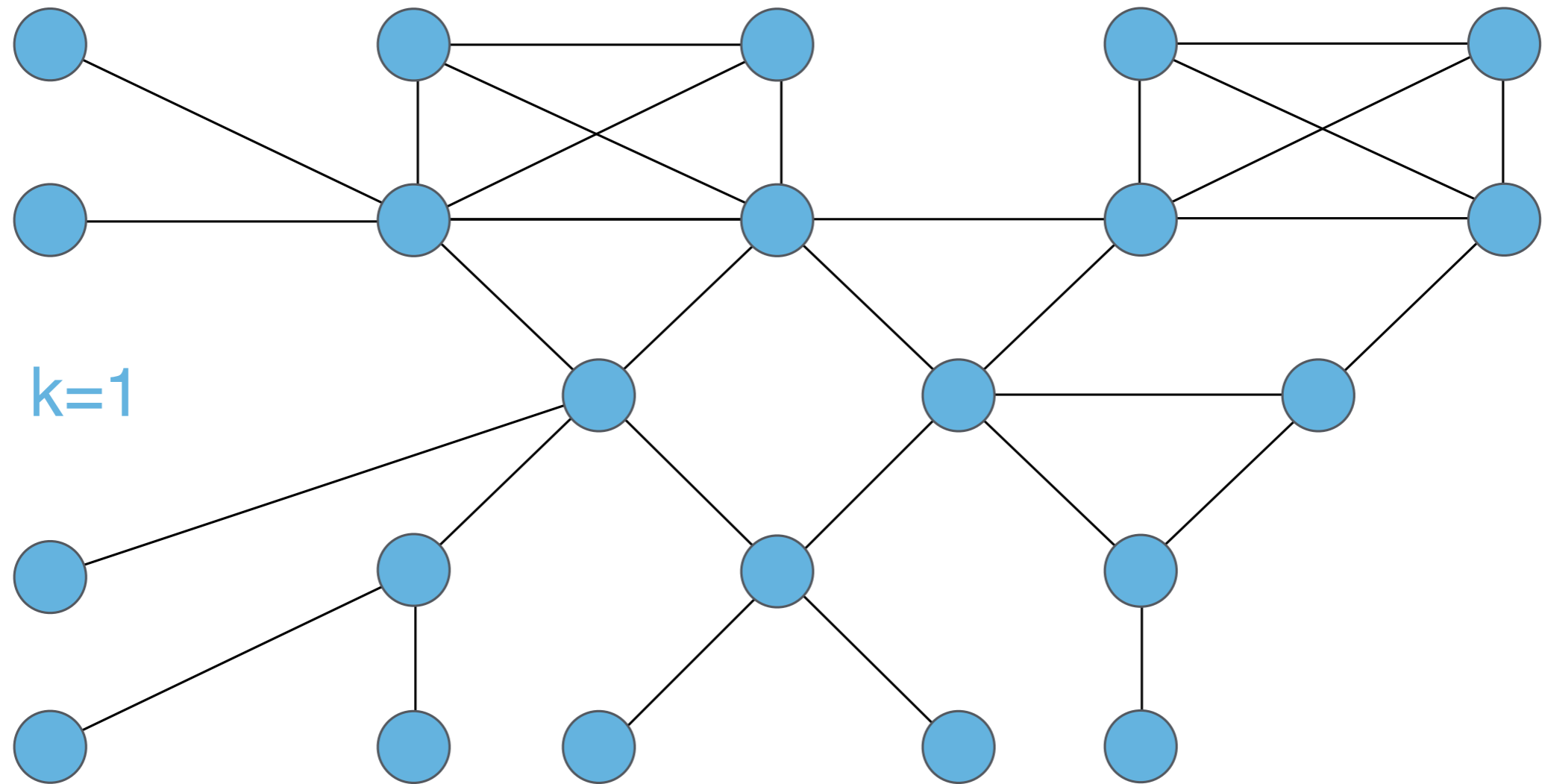

# Methodology: k-core decomposition

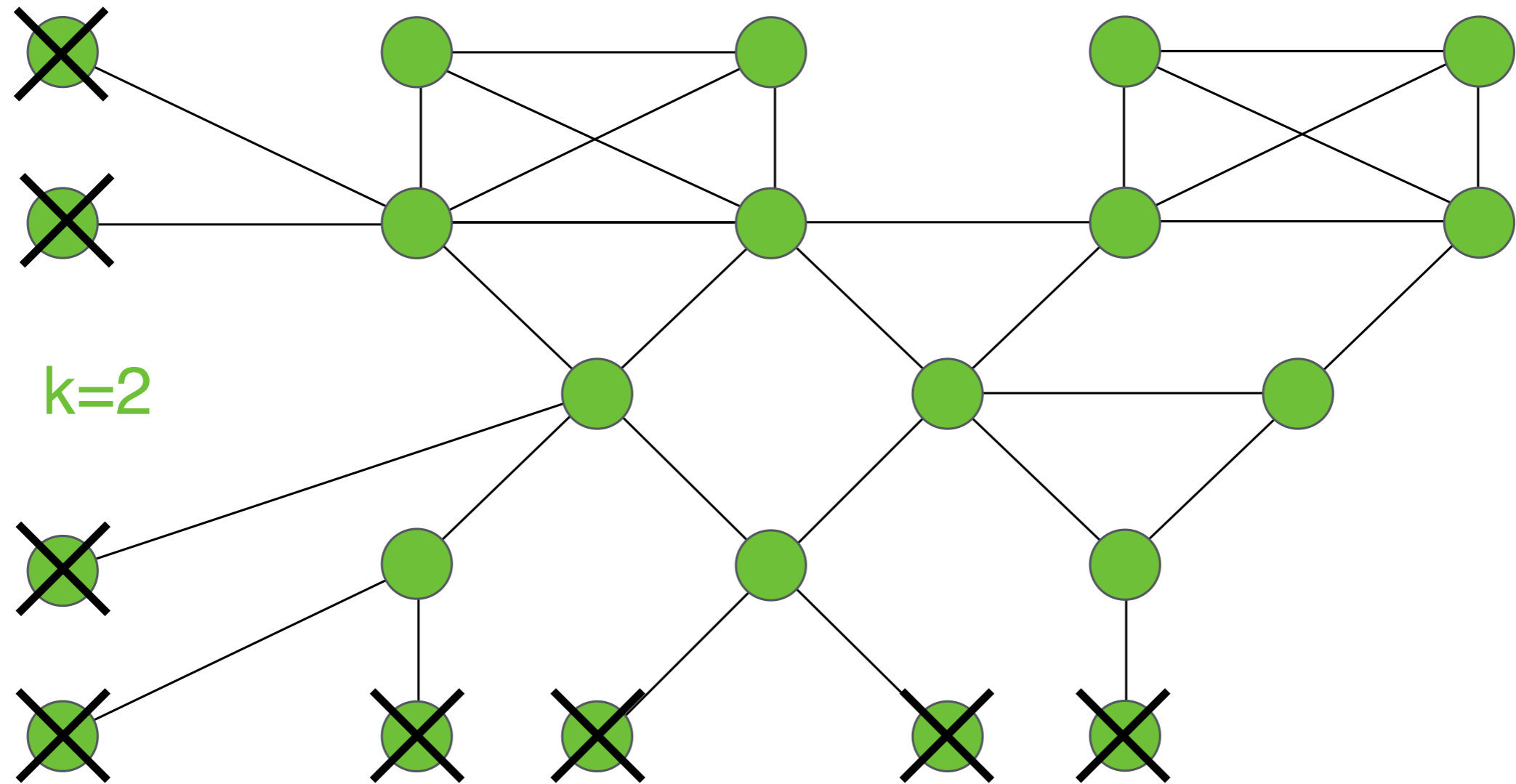

# Methodology: k-core decomposition

k=2

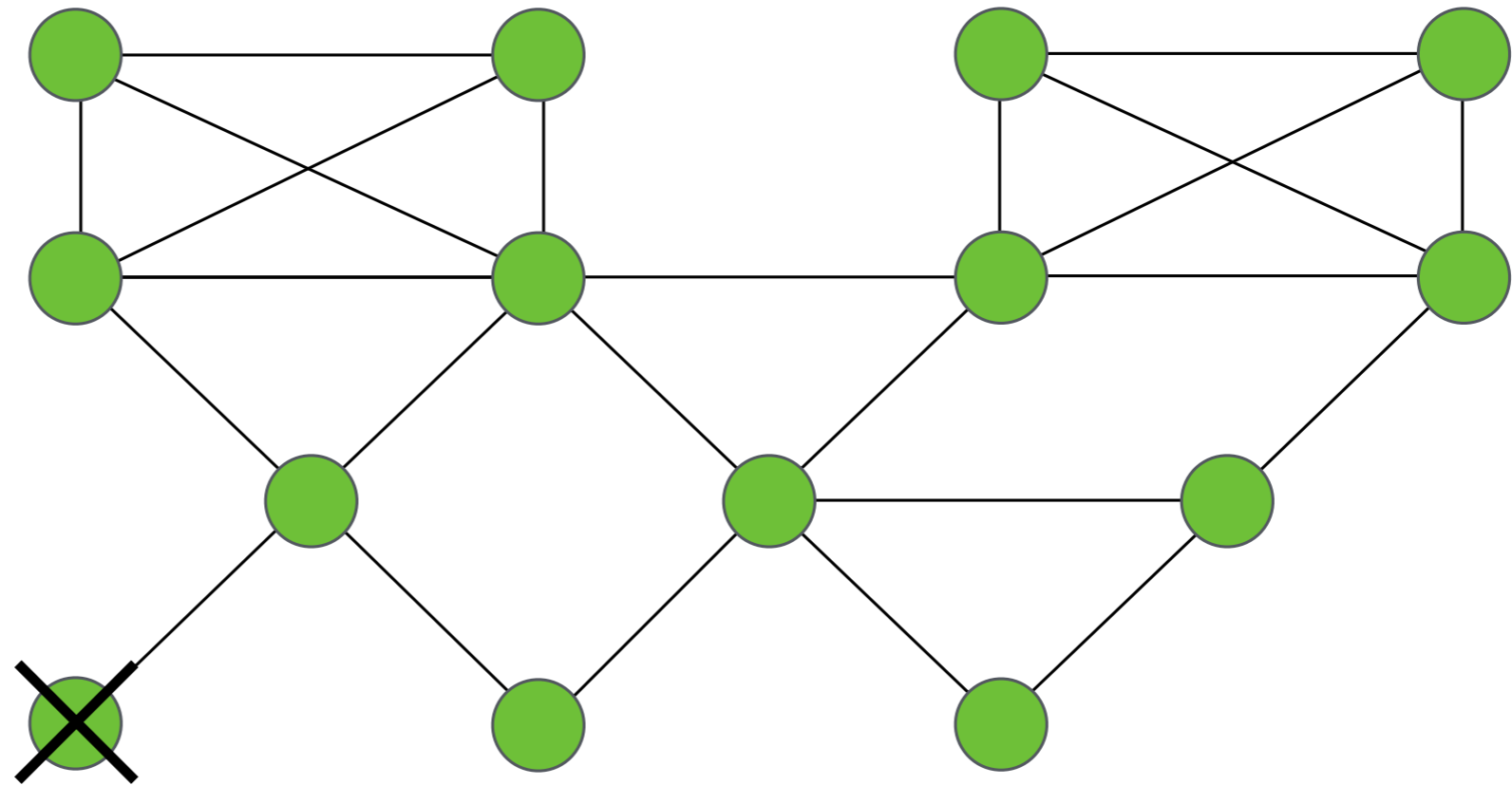

# Methodology: k-core decomposition

k=2

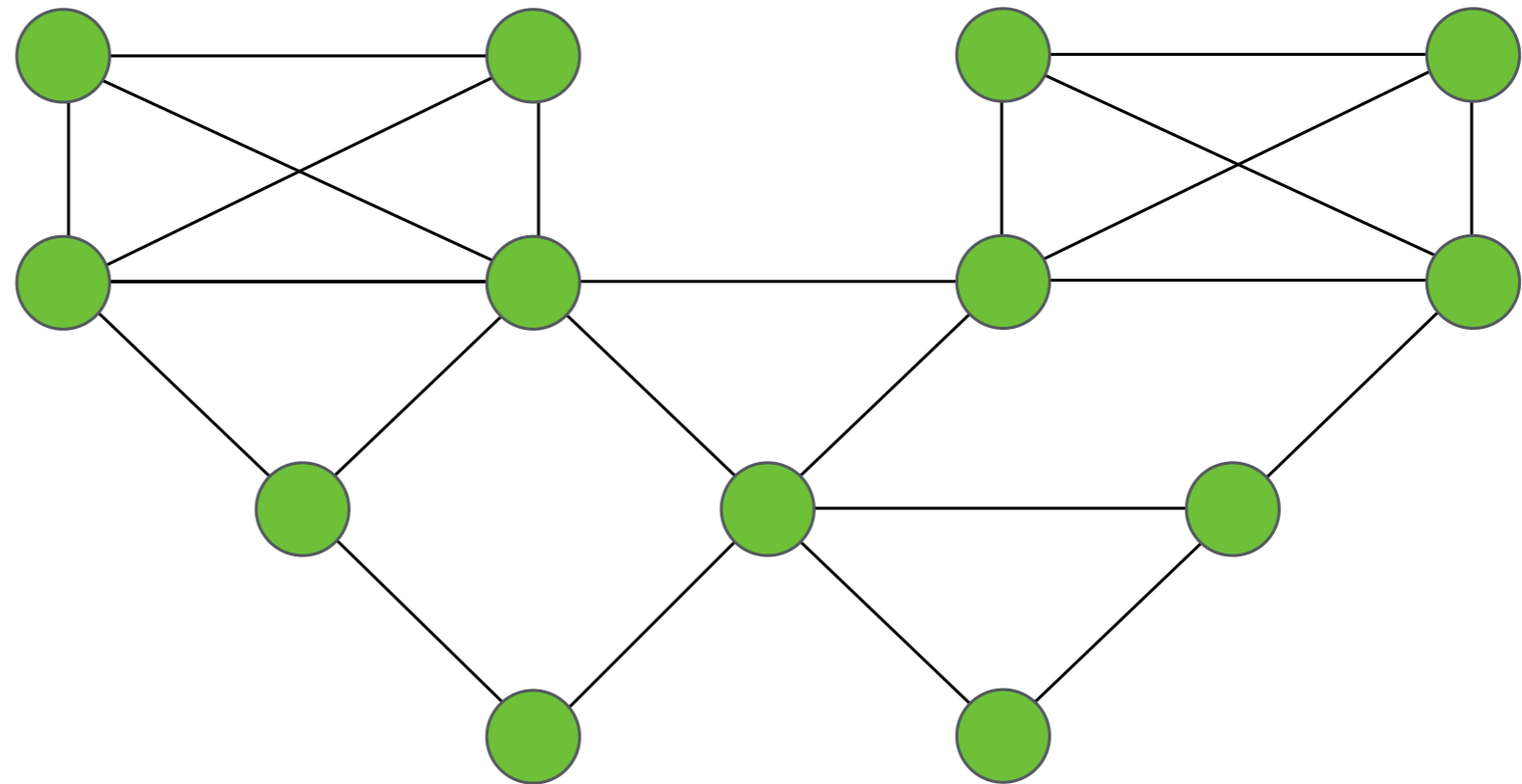

# Methodology: k-core decomposition

$k=3$

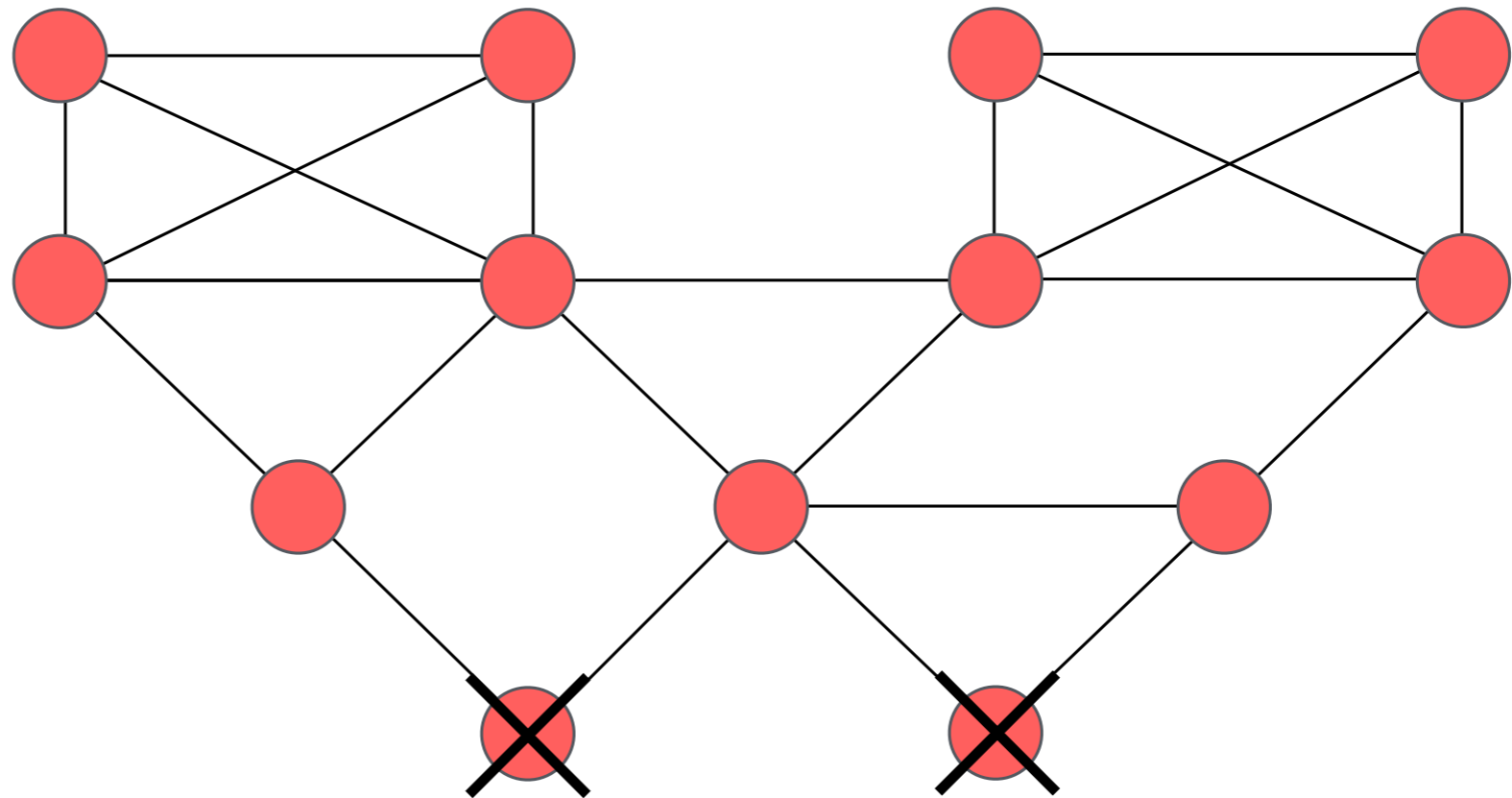

# Methodology: k-core decomposition

k=3

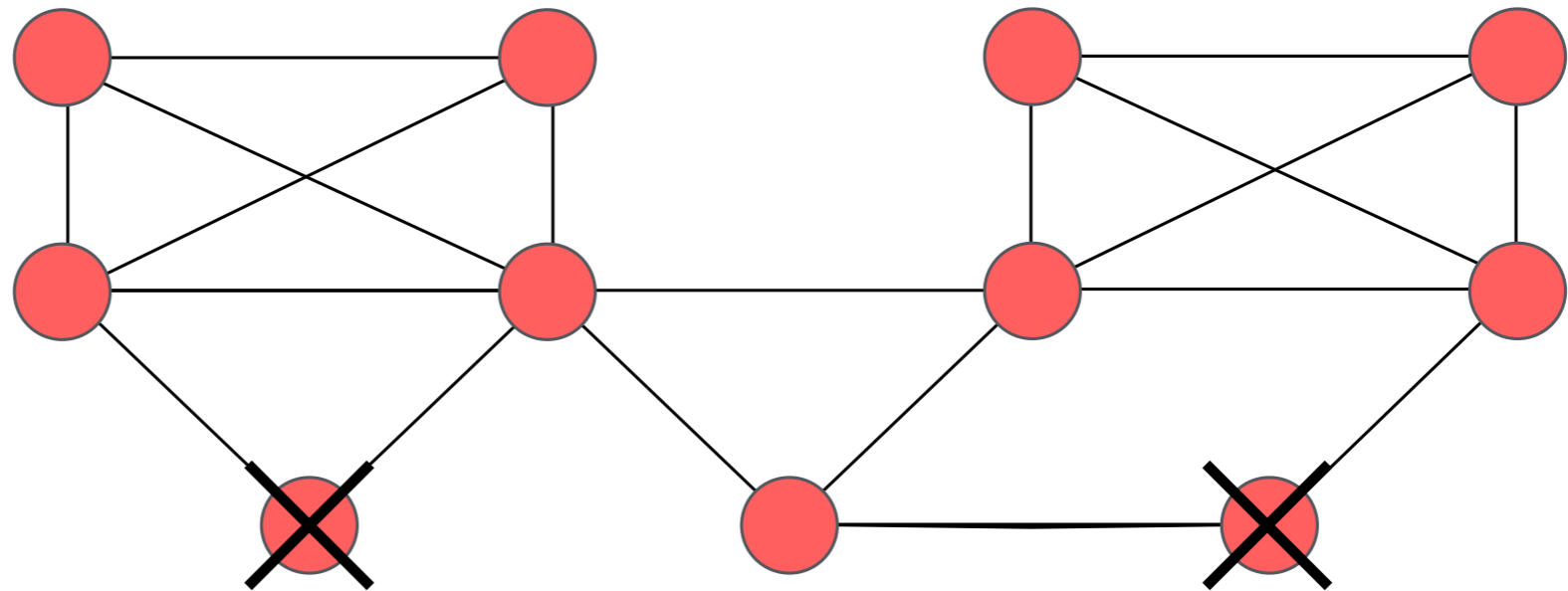

# Methodology: k-core decomposition

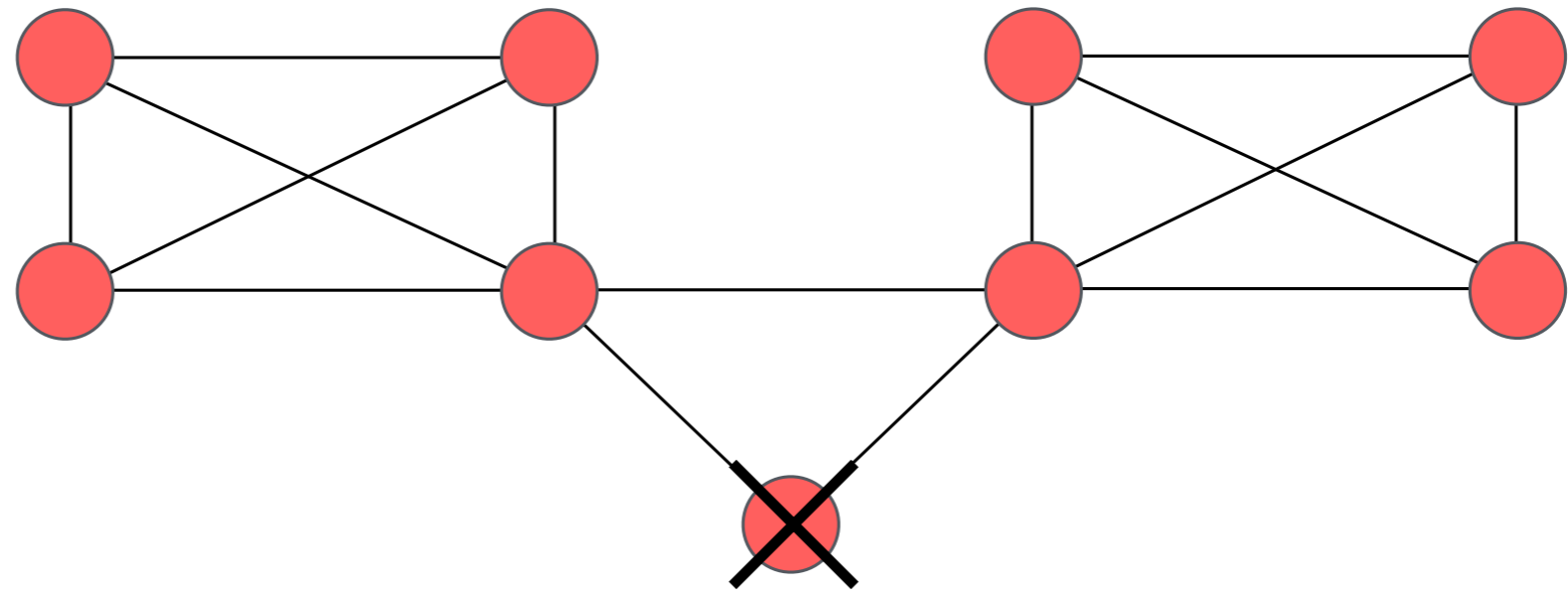

$k=3$

# Methodology: k-core decomposition



k=3



# Methodology: $k$ -core decomposition



$k=3$

## Conclusion

If a node belongs to core  $k$ , it has  $k$  neighbors node who have at least degree  $k$

# Methodology: k-core decomposition



$k=3$

**TOPcore:** The maximum core ( $k$ ) in the graph under analysis

# Dataset

- **Data sources**
  - CAIDA's publicly available data
  - BGP dumps
    - Routeviews
    - RIPE RIS
  - Ark Traceroute campaigns
- **Details about dataset**
  - Monthly snapshots of AS graph
  - Spans from 1999 to late 2017



# Analyses

1. Core evolution of large CPs (*Big Seven*) throughout the years
2. Geographical differences on the core evolution
3. Other members of the core

# Analyses

- 1. Core evolution of large CPs (*Big Seven*) throughout the years**
2. Geographical differences on the core evolution
3. Other members of the core

# Tracking the *Big Seven*



## Based on traffic statistics

- Sandvine report
- PeeringDB records

# Some caveats

## CPs may have several ASNs

- Focus on **primaries**

## In-network caches

- Content is often served from caches on ISPs' address space
- However, peering links are necessary to
  - fill caches, serve dynamic content and serve ISPs that are unwilling to host a cache

# Tracking the *Big Seven*

oct-2006

oct-2016

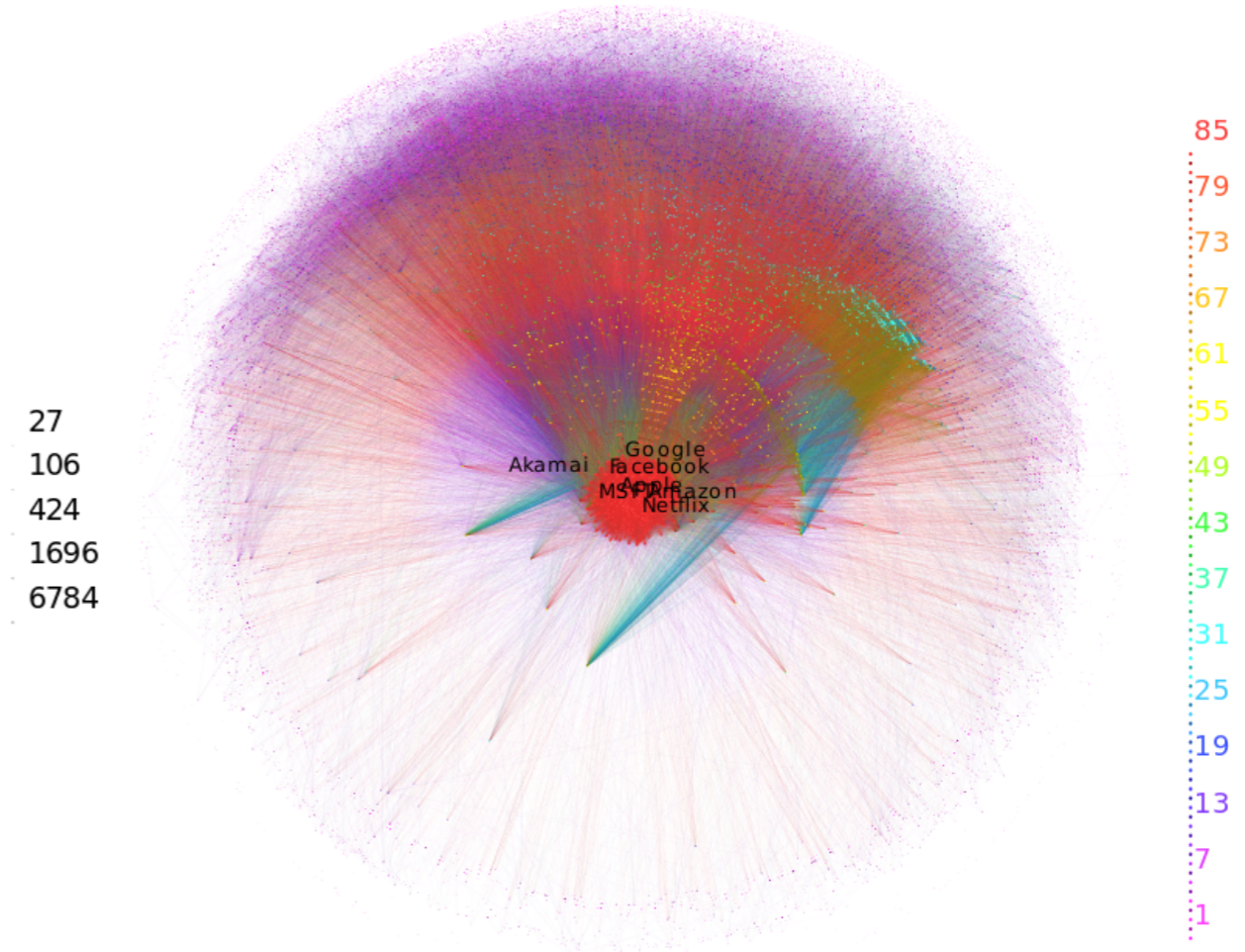
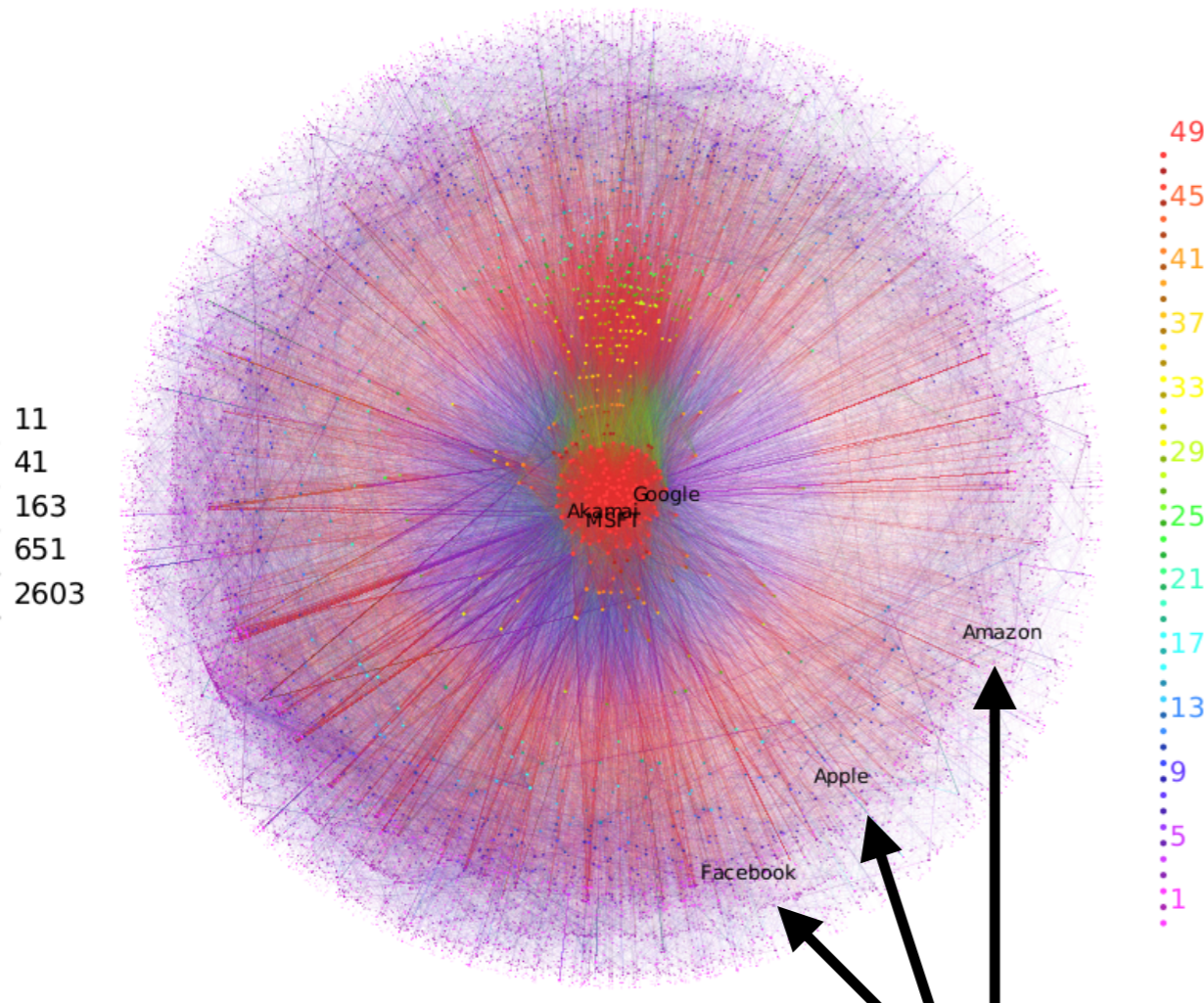

Facebook, Apple & Amazon

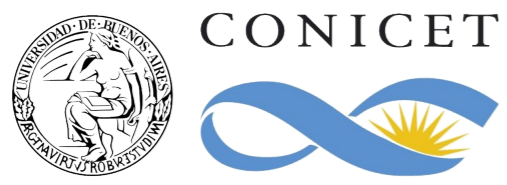

Studying the Evolution of Content Providers in the Internet Core  
June 28th, 2018. TMA 2018  
Esteban Carisimo



# Evolution of big seven

core evolution of CPs in Ark+BGP dataset

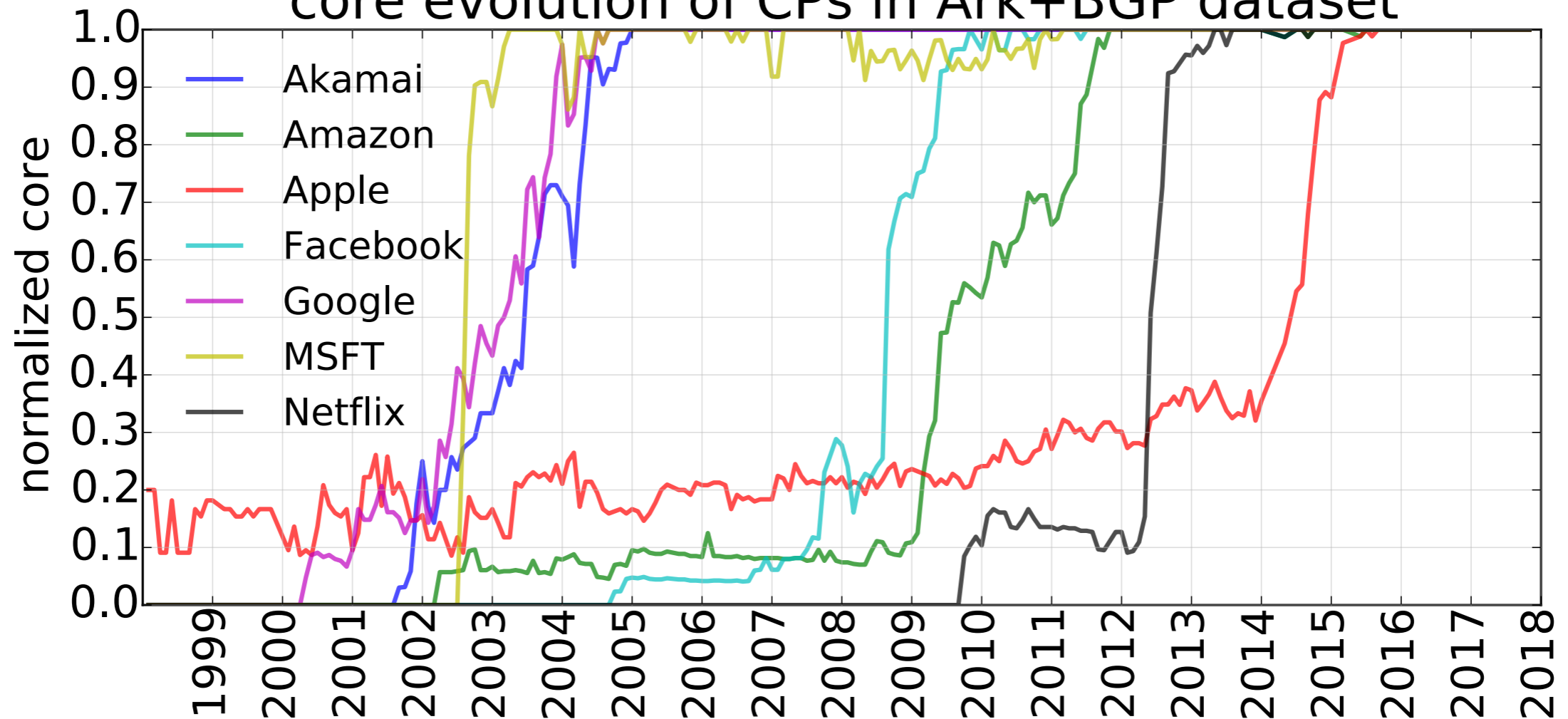

Studying the Evolution of Content Providers in the Internet Core  
June 28th, 2018. TMA 2018  
Esteban Carisimo

# Evolution of big seven

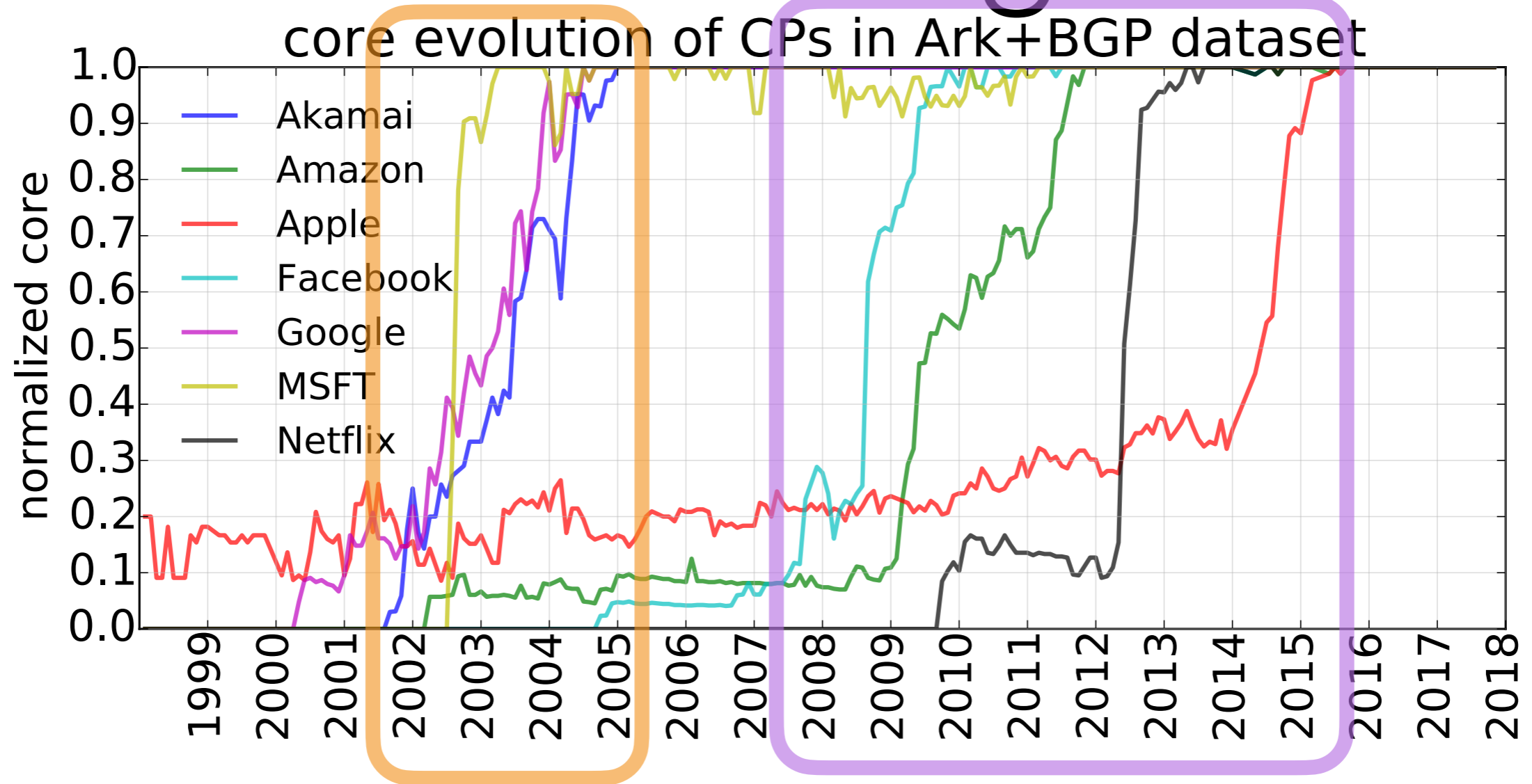

Some decades in the market

Recent offload from third-party CDNs



# Evolution of Amazon

core evolution of CPs in Ark+BGP dataset

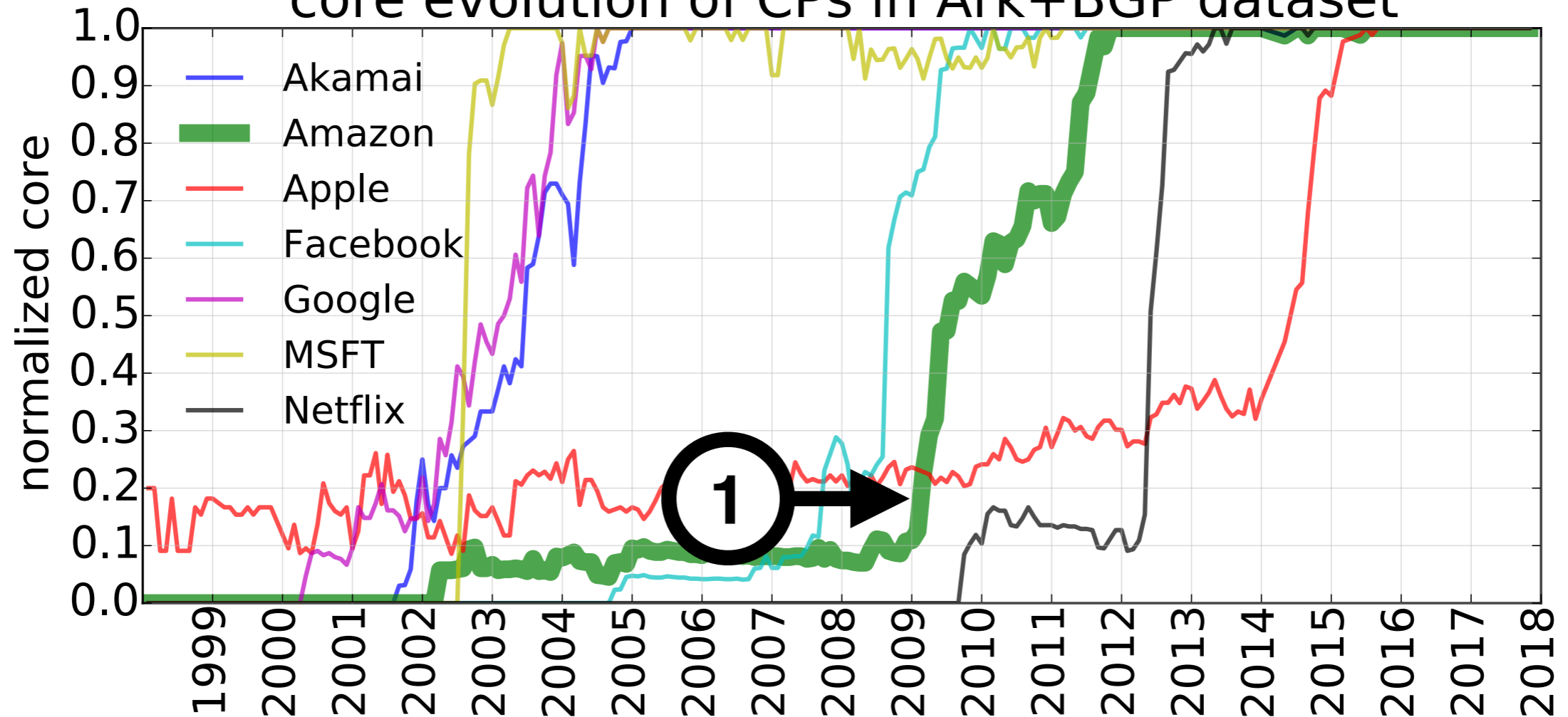

## 1. Release of DC in Northern California

# Evolution of Amazon

core evolution of CPs in Ark+BGP dataset

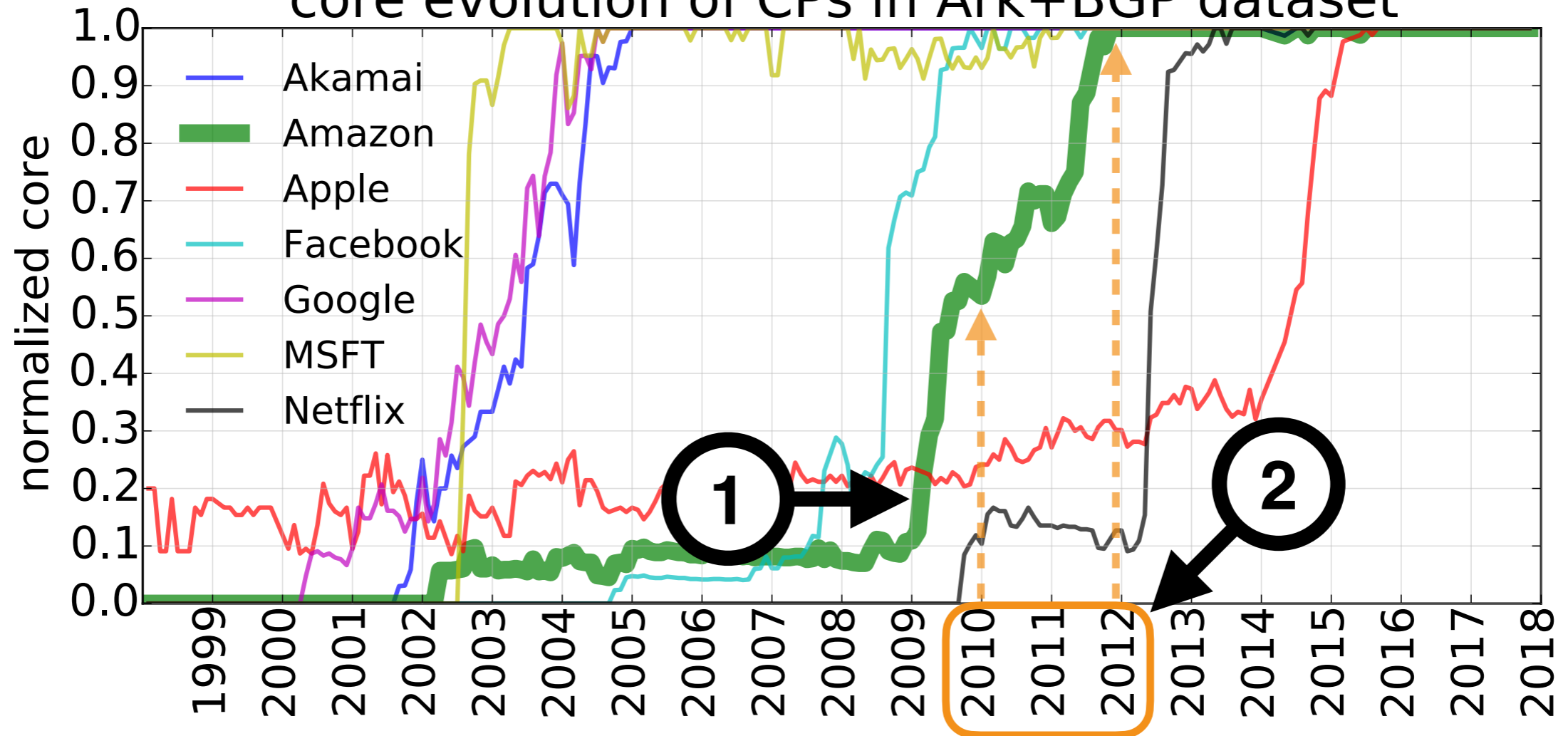

1. Release of DC in Northern California
2. Overseas expansion (Brazil, Europe & Asia)

# Evolution of Amazon

core evolution of CPs in Ark+BGP dataset

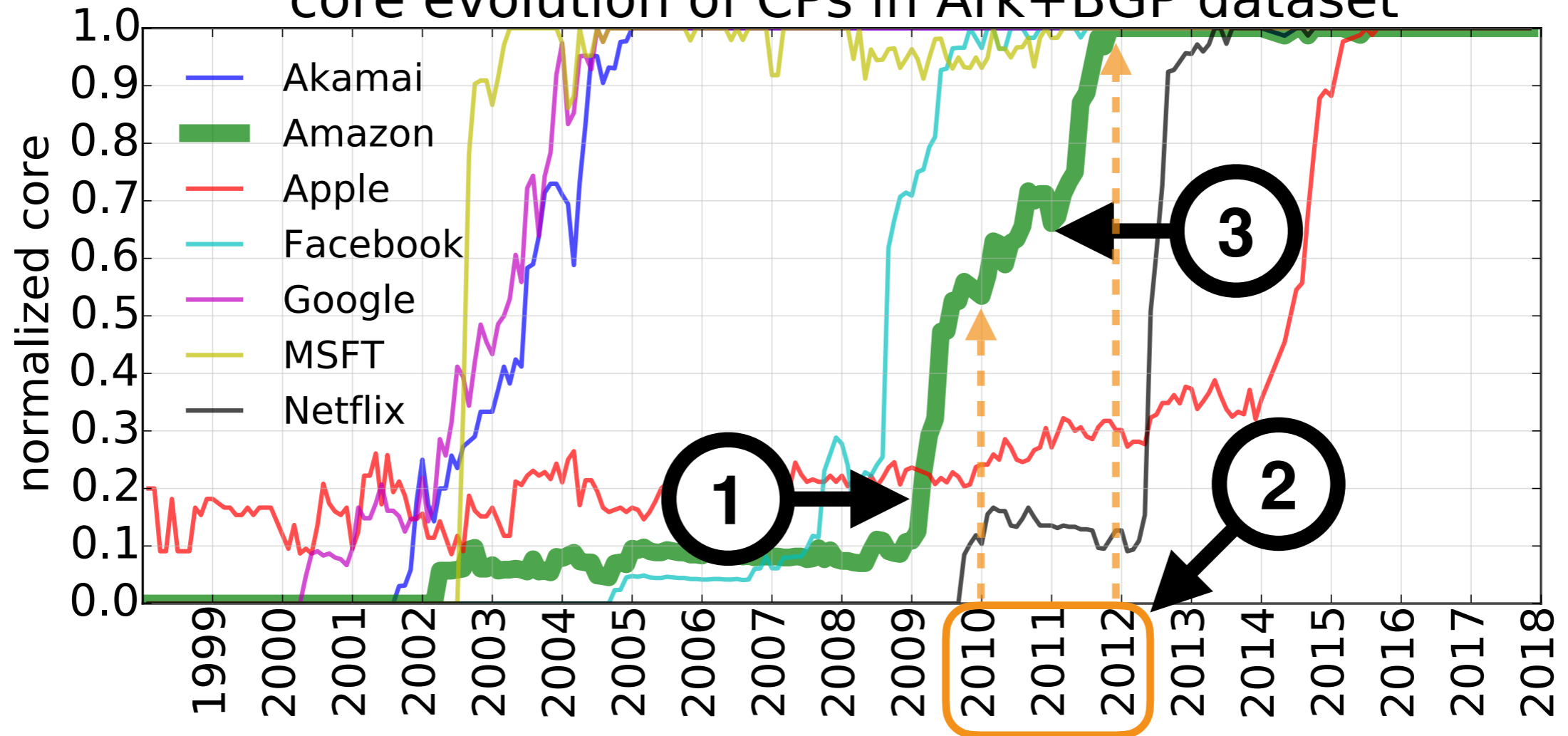

1. Release of DC in Northern California
2. Overseas expansion (Brazil, Europe & Asia)
3. Creation of WHOIS record for Amazon NS zone

# Evolution of Google

core evolution of CPs in Ark+BGP dataset

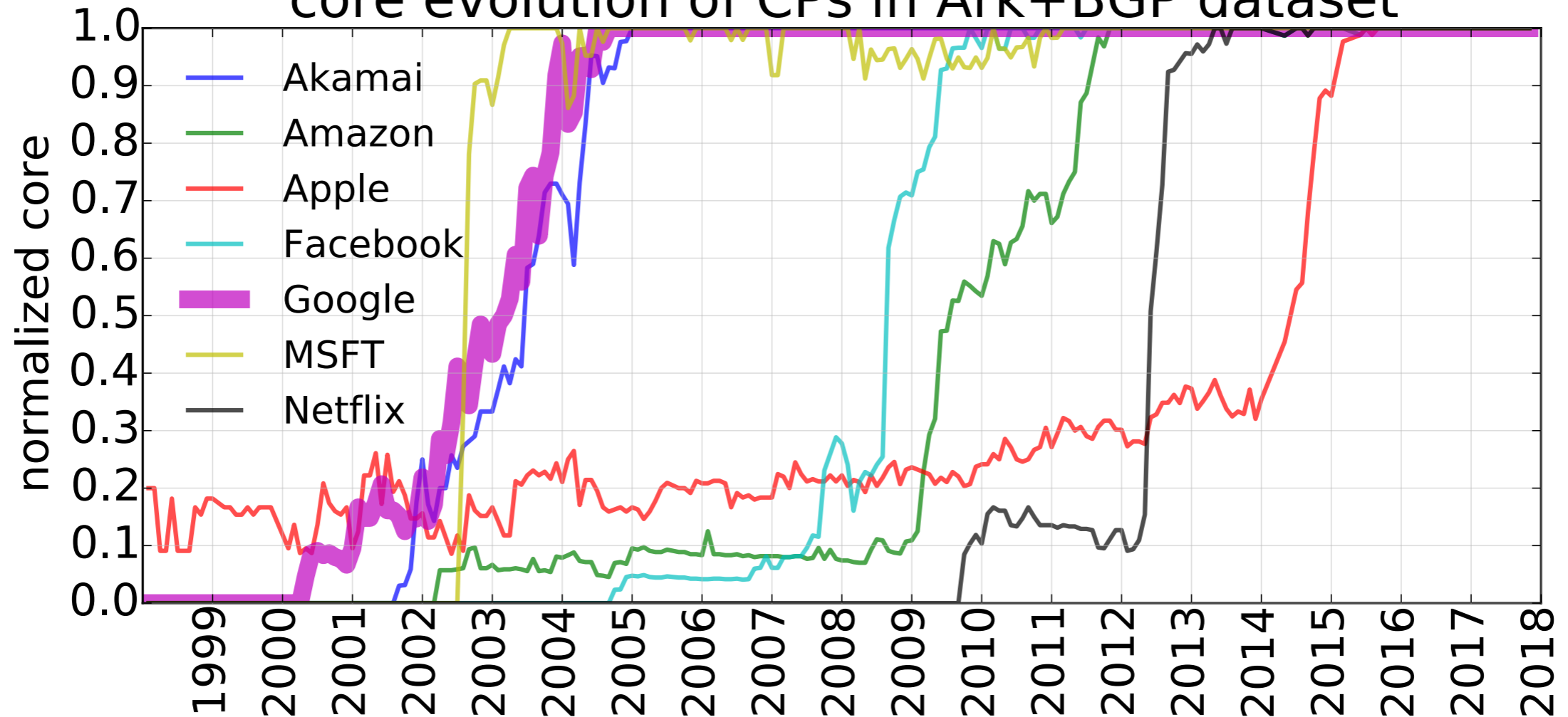

- Reached TOPcore before YouTube acquisition in 2006
- No CDN back then, but peer with TIER-1s

# Evolution of Netflix

core evolution of CPs in Ark+BGP dataset

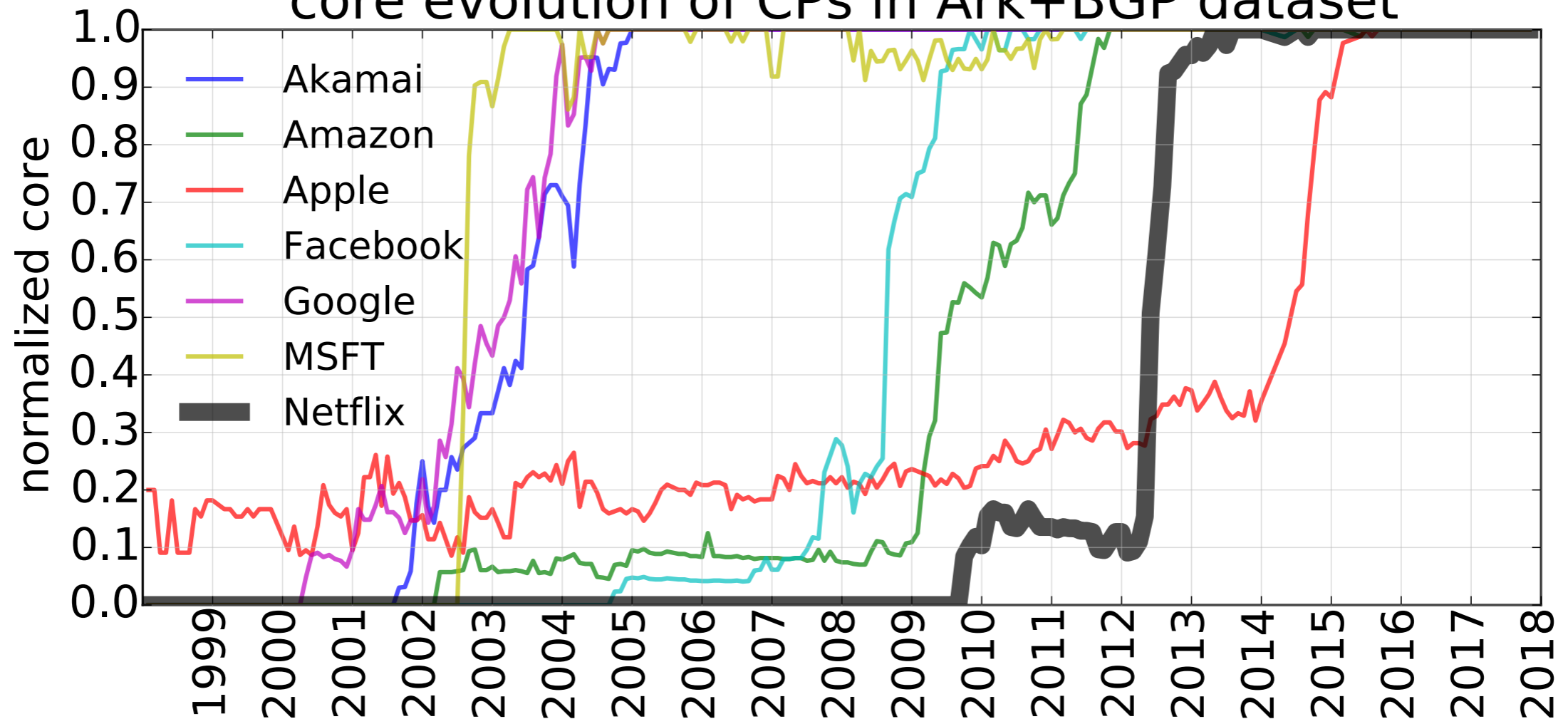

- Major source of traffic in the US since 2011
- In 2012 Netflix moved from Akamai to its own CDN
- OCA rollout led to some legal disputes

# Analyses

1. Core evolution of large CPs (*Big Seven*) throughout the years

**2. Geographical differences on the core evolution**

3. Other members of the core





# Analyses

1. Core evolution of large CPs (*Big Seven*) throughout the years
2. Geographical differences on the core evolution
- 3. Other members of the core**

# Other CPs in the core

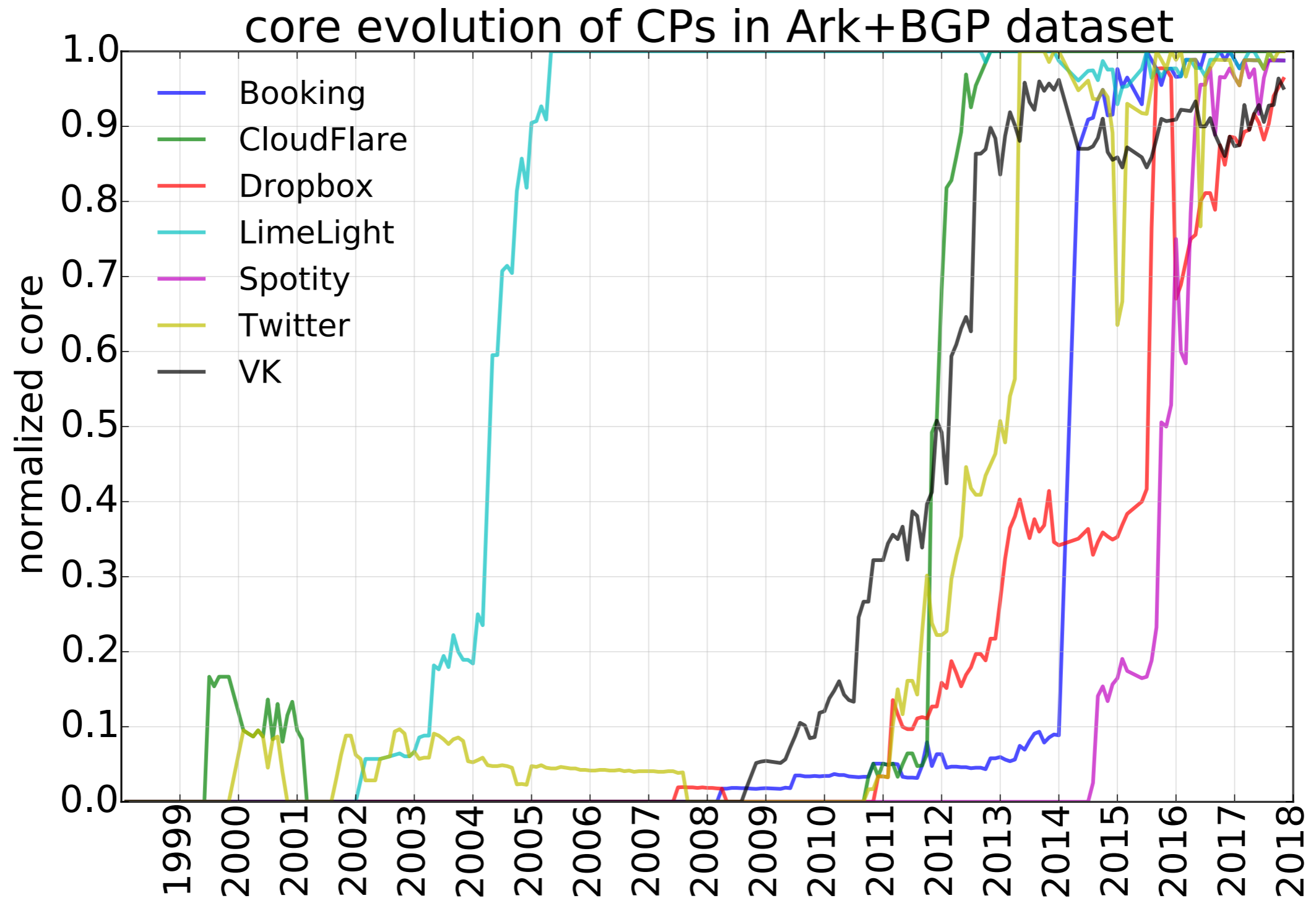

# Arrival at the core

Arrival of current TOPcore ASes at the TOPcore

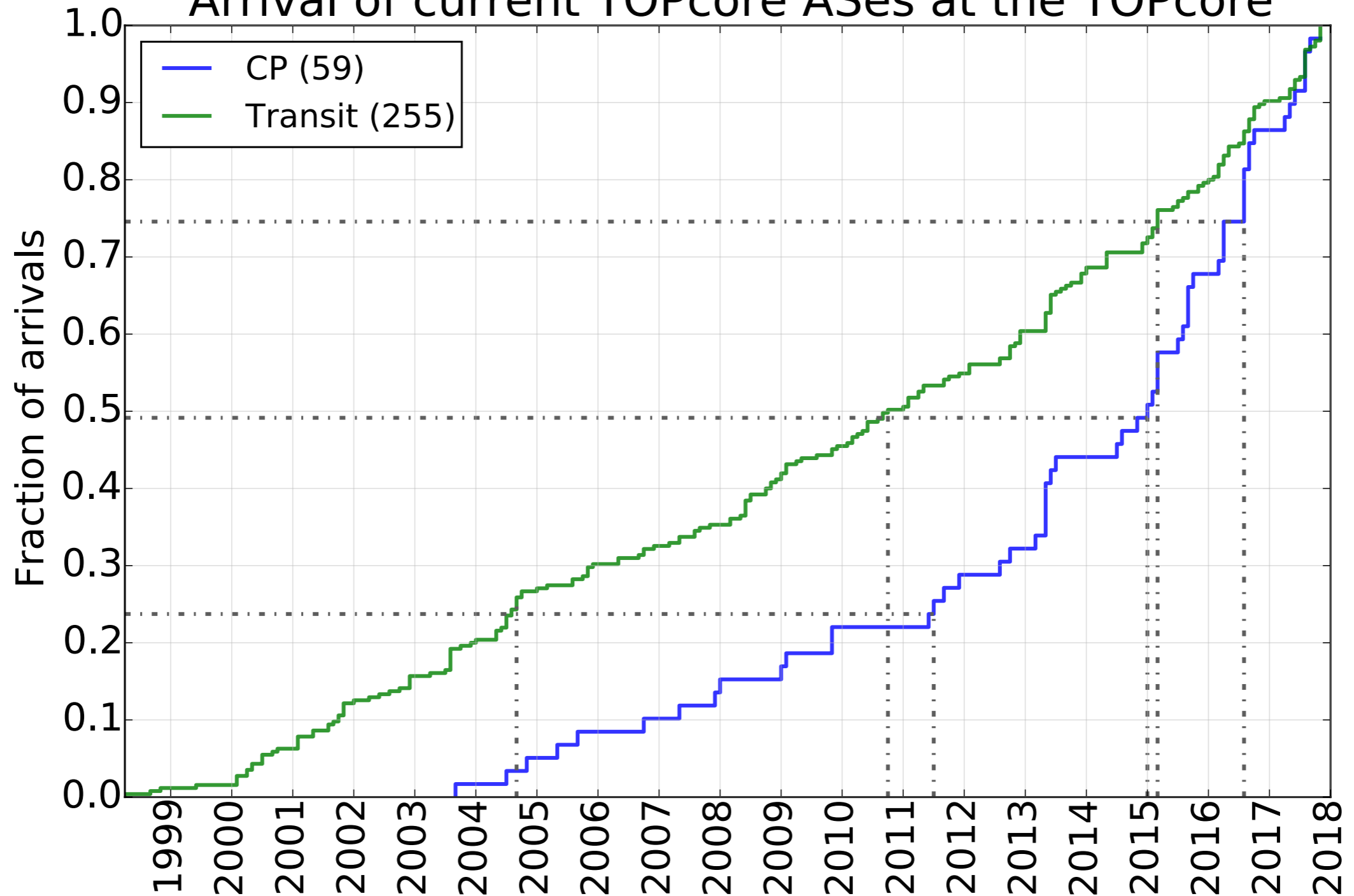

# Conclusions

- Large CPs deploy and run densely connected ASes
- Content is moving to private CDNs
- Match expansion of private CDNs with business strategies
- Create a website to allow users to look for other patterns

# Website

Content Providers towards the core of the network    Methodology    People

Download CSV    Download JSON

AS Number	Short Name	AS Type	Country	From Th.=0.3	To Th.=0.9	Grow Months
AS31252	STARNET-AS		MD	2009 / 7	2009 / 8	1
AS31283	FASTHOST-AS		NO	2007 / 10	2008 / 4	6
AS31477	DUOCAST-AS		NL	2007 / 10	2008 / 4	6
AS31500	GLOBALNET-AS		RU	2007 / 10	2008 / 4	6
AS32934	FACEBOOK		US	2008 / 7	2009 / 5	10
AS33926	-Reserved AS-		ZZ	2007 / 10	2008 / 10	12
AS34288	AS34288 EDU-ZG-CH		CH	2010 / 8	2011 / 1	5
AS34695	E4A-AS		IT	2008 / 5	2008 / 8	3
AS35425	BYTEMARK-AS		GB	2010 / 7	2011 / 5	10

First    Prev    1    2    Next    Last

K-Core evolution for selected ASs

Visit: <http://cnet.fi.uba.ar/TMA2018>



Studying the Evolution of Content Providers in the Internet Core  
June 28th, 2018. TMA 2018  
Esteban Carisimo

# Thanks!

# Questions?

